

smart packaging solutions by manufacturers



Alpha-Pack Enterprise Co. Ltd.

Address: Unit 1406, Vanta Industrial Centre, 21-23 Tai Ling Pai Road, Kwai Chung, Hong Kong

Tel.: 852-2416-1237

Fax.: 852-2264-6540

E-mail: sale@alpha-pack.com.hk

Website: www.alpha-pack.com.hk



LASER CUTTING MACHINE



數控折彎機 CNC BENDI

Company Profile

Alpha-Pack Enterprise Limited was established in 1994 in Hong Kong. Alpha-Pack is a comprehensive enterprise that dedicated in packaging machinery in last 20 years; it combines R&D, production, marketing and service together.

Since the company has been founded, Alpha-Pack cooperated with many famous European packaging machinery manufacturers to make the packaging machinery for worldwide market. As the name in Chinese “欧华”, means we made the machine with European standard but in Chinese manufacturing cost. Thanks to the trust from all the business partners, customers and staffs, Alpha-Pack has been grown as one of the biggest packaging machinery manufacturing group in South China, with more than 80,000 m² manufacturing workshops in China and Europe, Alpha-Pack became the leading packaging manufacturer in China for the following categories of packaging machineries:



CNC MANUFACTURING CENTER



數控車床 CNC LAT

- ▶ Shrink packing machine
- ▶ Vertical Form Fill Seal and Flow Wrapper
- ▶ Thermo sealing & MAP
- ▶ Flow wrapper
- ▶ Pre made pouch filling and sealing machine
- ▶ Filling, capping and labeling machine
- ▶ Vacuum Machine



機車間
machine workshop



給袋機車間
Doypack machine workshop

Corporate Culture

- ▶ All our staffs will, as always, be pursuing a consistent concept that “we do better than you expected” to serve our domestic and worldwide customers.
- ▶ Grateful to customers trust and support, all Alpha-Pack members promise to develop the best products, provide the best service, and create the best brand with a very reasonable price. Create value and profit for our clients.
- ▶ We believe integrity and quality service are the best way to build up long term customer relationship.



Automatic gusset pouch open and sealing machine

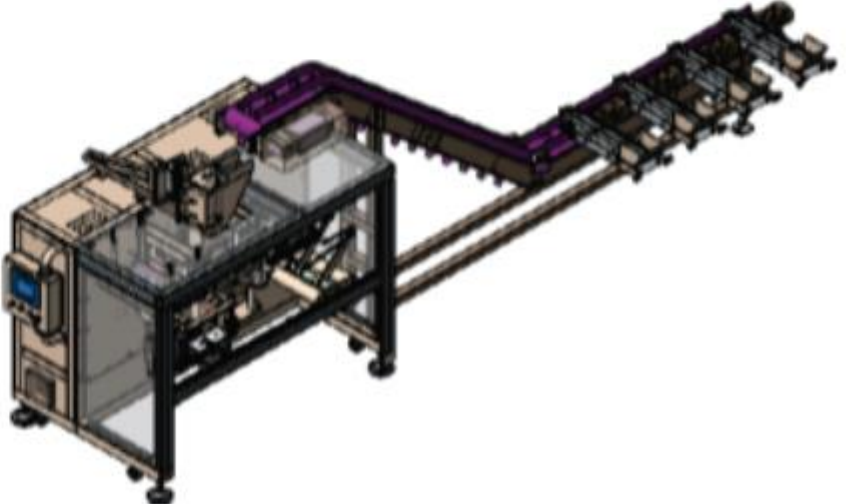
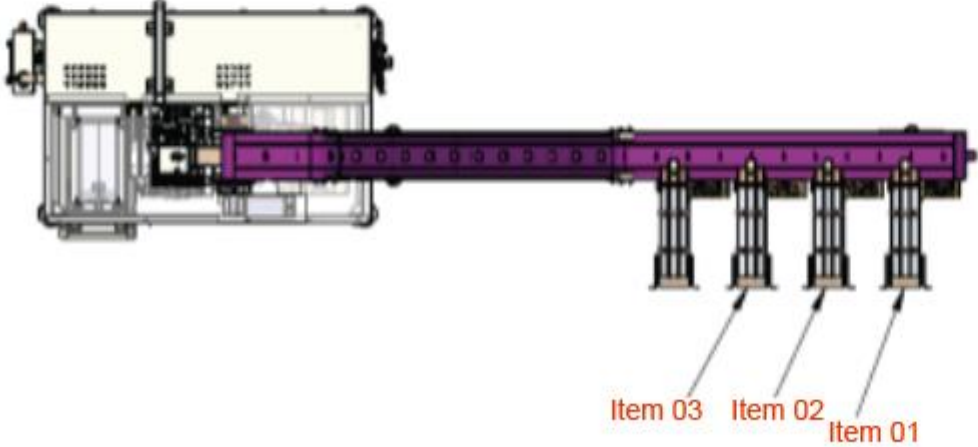
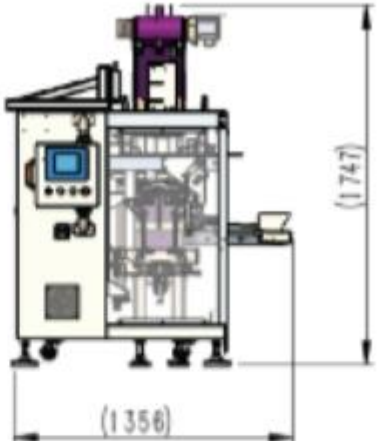
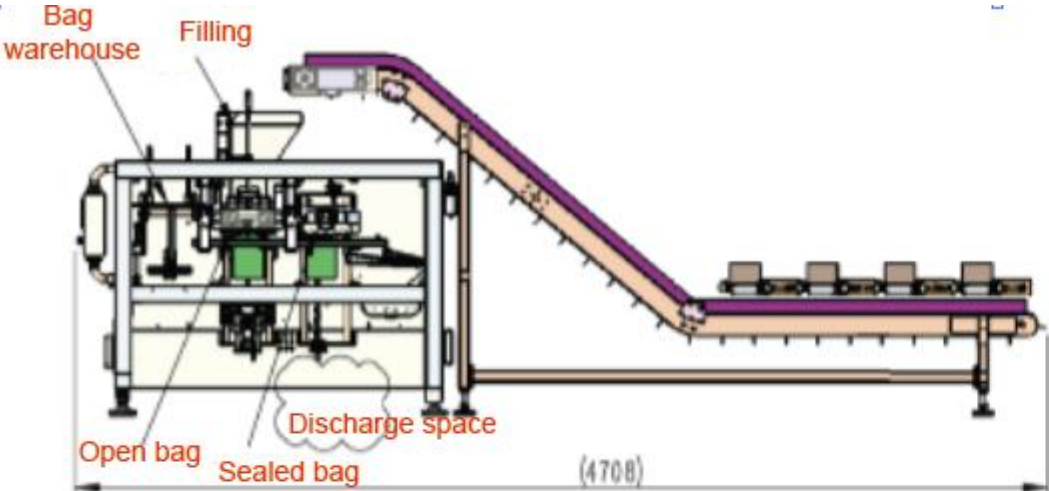

Automatic gusset pouch open and sealing machine

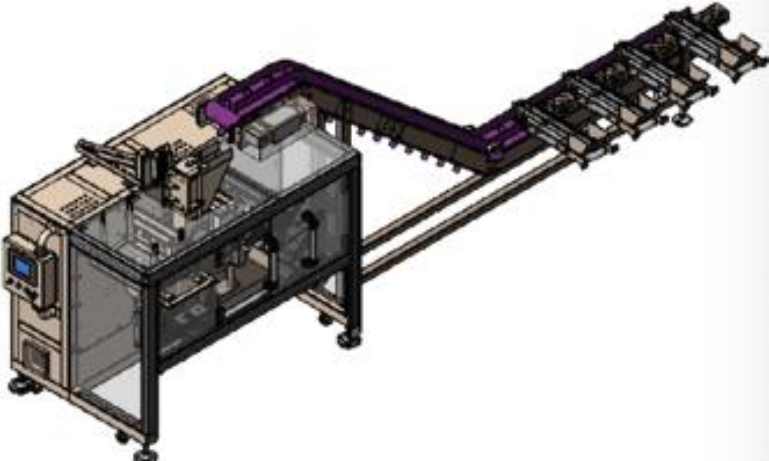
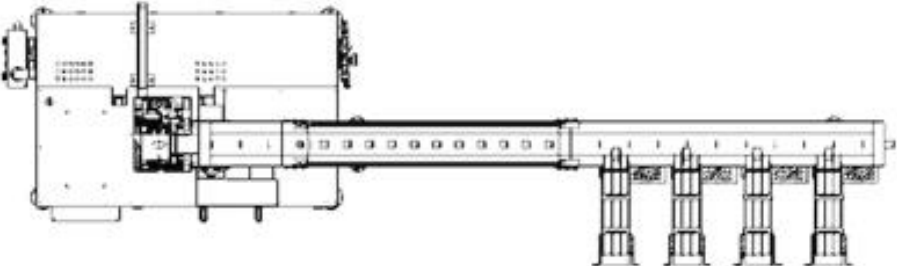
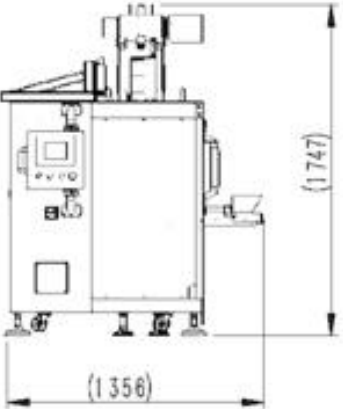
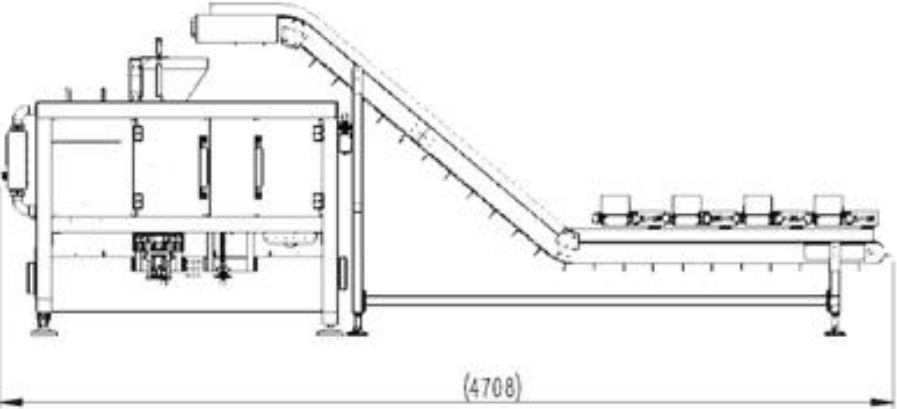

Coffee Bean Pouches



Square Bottom bag with clear gusset



Square-Bottom Gusset Bags



Foil Gusseted bags



Plantation Gusseted Bag



Quad-Seal Gusseted Bags



Paisley Gusseted bag



Poly Gusseted Bag



Foil Square Bottom Gusseted bag with E-zip



Product Sample

Application:

AP-3BT is special designed for gusseted premade pouch packaging application.

Suitable for following pouch:

1. Coffee Bean Pouch
2. Square bottom bag with clear gusset
3. Square-Bottom gusset bags
4. Foil Gusseted bags
5. Plantation Gusseted Bag
6. Foil square bottom gusseted bag with E-Zip
7. Quad-Seal gusseted bags
8. Paisley gusseted bag

Mix-match various dosing unit, it could be filled the related products, such as below,

Powder: Coffee powder, Wheat flour, Soup, etc... - (By use auger System)

Granule: Coffee beans, Sugar, Seasoning, etc.... - (By use Volumetric Measure or Scales)



Standard Feature:

1. 2 stations in linear design.
2. Build in Vertical Pouch Feeding Magazine.
3. Build in Vacuum Pump for bag pick up and opening
4. Build in Vibration holding device
5. Panasonic PLC + Kinco 7" color screen
6. Standard 304 stainless steel case.
7. Interlock safety door protection.

Optional Items:

1. Air type vacuum refilling device
2. Air Blower refilling device
3. Auger refilling device
4. Z-type bucket elevator
5. S-type refilling conveyor
6. Printer
7. Labelling machine
8. AB or Siemens PLC & Screen
9. Festo pneumatic components
10. Air remove device
11. Collection rotary round table

Technical Specification

| | |
|--------------|-----------|
| Model | AP-3BT |
| Pouch Width | W 100-200 |
| Gusset Depth | D 60-140 |
| Pouch Length | L 150-400 |
| Speed | 10-15ppm |





- *Alpha Pack-Germany*
- *Alpha Pack-Italy*
- *Alpha Pack-USA*
- *Alpha Pack-Columbia*



***We do better than your
expectation!!***

smart packaging solutions by manufacturers

